

V DISPENSERS ISCOTROLL DC



EN. Independent mobile unit without using compressed air or power mains, for oil dispensing anywhere. Trailer mounted support for moving the drums. Self-priming pump with 12 VDC motor, protection rating IP 55.

Options:
Flow meter with oval gears.

RU. Независимый мобильный блок для подачи масла в местах, в которых отсутствует компрессор сжатого воздуха или розетка электросети. Опора с тележкой и держателем бочки. Самозаливающийся насос с двигателем постоянного тока на 12 В, степень защиты IP55

Дополнительно:
Счетчик литров с овальными шестернями.

DE. Unabhängige, fahrbare Einheit, mit der man auch dort Öl abgeben kann, wo keine Pressluftanlage oder Steckdose vorhanden ist. Fahrbarer Fassträger. Selbstansaugende Pumpe mit 12 V-Gleichstrommotor; Schutzklasse IP55

Sonderausstattungen:
Literzähler mit ovalen Rädern.

PERFORMANCE

- Flow rate up to 6 l/min
- Accuracy +/- 0,5 %
- Viscosity up to 2000 cSt
- Noise level below 65 dB
- Engine power supply voltage 12 Vdc
- Switching on/ off of automatic pump with pressure switch

- Расход до 6 л/мин
- Погрешность +/- 0,5%
- Вязкость до 2000 сСт
- Уровень шума ниже 65 дБ
- Напряжение питания двигателя 12 В пост. тока
- Автоматическое включение/выключение насоса благодаря реле давления

- Durchflussmenge bis 6 l/Min.
- Abgabegenauigkeit +/- 0,5 %
- Viskosität bis 2000 cSt
- Lärmpegel unter 65 dB
- Versorgungsspannung Motor 12 V DC
- Automatisches Ein-/Ausschalten der Pumpe über Druckschalter

DIMENSIONS

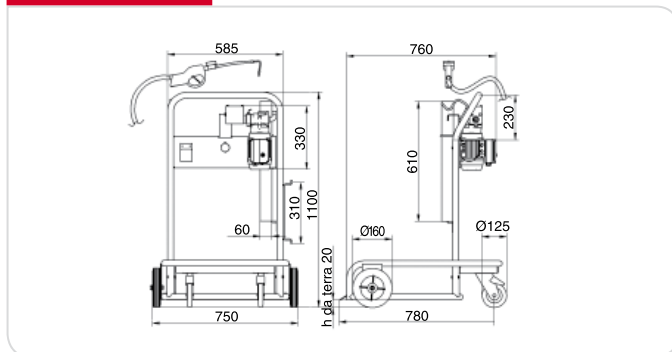

Drum not included

PRODUCTS' RANGE WEIGHT AND PACKAGING

Code	Weight		Packaging		
	kg	lbs	mm	inch	pcs/box
VISCOTROLL 120/1					
F00263200	57	125,7	1090x690x320	42,9x27,2x12,6	1
F00263210	58	125,9	1090x690x320	42,9x27,2x12,6	1
F00263220	58	125,9	1090x690x320	42,9x27,2x12,6	1

Flow-rate
up to
6 l/min
(up to 1,6 gpm)

Accuracy
+/-
0,5 %

Viscosity
up to
2000 cSt



DISPENSERS



Drum not included

Optional: flow meter with oval gear

Viscotroll DC



PUMPS

METERS

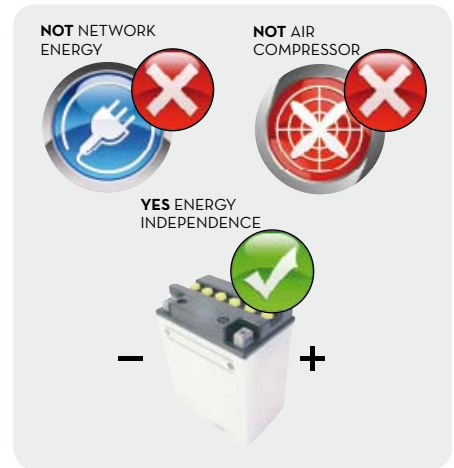

NOZZLE METERS

NOZZLE

SPECIAL EQUIPMENTS

FEATURES



Gear pump



Adjustable bypass valve



On demand dispensing



Battery charger

ON REQUEST

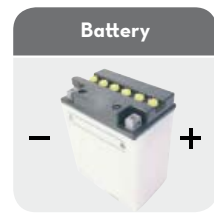

Battery



Troll

Code R12068010

FLUID MONITORING

ACCESSORIES

FILTERING

PRODUCTS' RANGE TECHNICAL DATA

Code	Description	Fluids type	Flow-rate		Battery charger Volt	Viscosity cSt max.	Voltage			Meter mod.	Pump mod.	Nozzle type
			l/min	gpm			AC V/Hz	DC Volt	Power Watt			
F00263200	Viscotroll 120/1 DC pst.	☐	6	1,6	230	2000	12	360	30	K400	Viscomat DC	Easyoil
F00263210	Viscotroll 120/1 DC pst. K400	☐	6	1,6	230	2000	12	360	30	K400	Viscomat DC	Easyoil
F00263220	Viscotroll 120/1 DC pst. K400 100V/120V	☐	6	1,6	120	2000	12	-	-	K400	Viscomat DC	Easyoil